

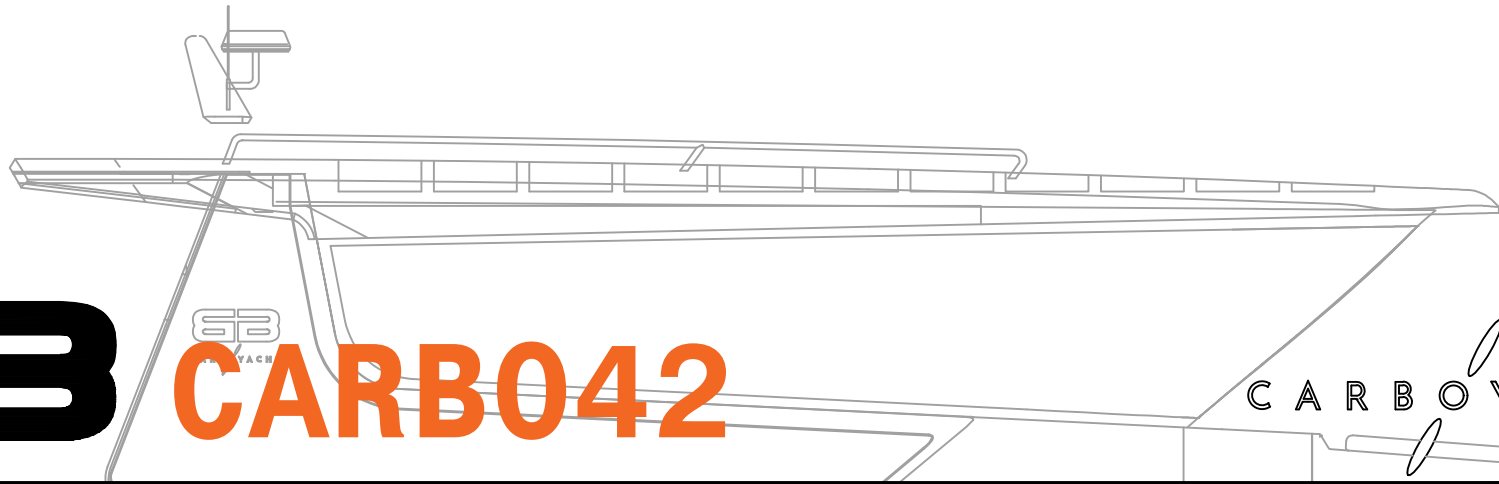

CARBO42

CARBOYACHT



MANUFACTURER	CARBO YACHT YATÇILIK A.Ş.
BOAT / CRAFT TYPE	MOTORYACHT - CARBO42
CERTIFICATION	C INSHORE MODULE B
LENGTH OVERALL	13.40 M
HULL LENGTH	11.88 M
BEAM	3.90 M
DRAFT	1.00 M
DISPLACEMENT	7800 KG
MAIN ENGINES	2 x 79HP NANNI D / 2 x 75HP VOLVO PENTA
SPEED	CRUISING SPEED 11 KNOT MAXIMUM SPEED 15 KNOT
FUEL CONSUMPTION	AT CRUISING SPEED 10 LT 2 ENGINES AT MAXIMUM SPEED 30 LT 2 ENGINES
RANGE WITH FULL FUEL TANK	WITH CRUISING SPEED 800 MILES
FUEL TANK CAPACITY	1 x 750 LT
FRESH WATER TANK CAPACITY	1 x 300 LT
GREY WATER TANK CAPACITY	1 x 200 LT
BLACK WATER TANK CAPACITY	1 x 200 LT
ELECTRONICS	GPRS GARMIN 7", CHART, VHF DEPTH, SPEED and WATER TEMPERATURE LOG
WINDLASS	QUICK 12V 1500W
STAINLESS STEEL ACSESSORIES	AISI 316L STAINLESS STEEL
DECK FLOORING	INFINITY TEAK FLOORING 10 YEAR WARRANTY, ORTHOPEDIC
NUMBER OF CABINS	2 PCS MASTER CABIN
NUMBER OF SHOWER - WC	2 PCS SHOWER - WC
GALLEY	MAIN DECK
WHITE GOODS GROUP	1 PC TELEVISION with LIFTING MECHANISM 1 PC REFRIGERATOR 1 SET OVEN - HOB WITH GAS
OPTIONAL LIST	AIR CONDITIONING GENERATOR WATER MAKER AUTOPILOT BOW THRUSTER STERN THRUSTER PASSACRANE / GANGWAY WASHING MACHINE DISHWASHER BOILER / WATER HEATER TELEVISION ON CABINS TENDER LIFT

Desired IPS or INBOARD ENGINE can be used up to 400 HP with total 2 engines.

The curves above are tests made while complying with standarts.

Boat speed tested with tanks are 25% full and with 4 staff.

Brands may vary, this rights belongs to the COMPANY.